







SCALA 3T SPLIT MODULAR FLAKE ICE MACHINE SPLIT

FEATURES CARACTERISTICAS

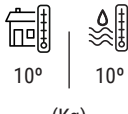
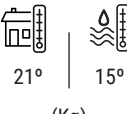
- ▶ **PRODUCES FLAT FLAKES THAT ARE VERY COLD AND DRY. THICKNESS MAY BE CHANGE BETWEEN 1.5 AND 3 mm**
PRODUCE ESCAMAS PLANAS MUY FRÍAS Y SECAS. EL ESPESOR PUEDE REGULARSE ENTRE 1.5 Y 3 mm
- ▶ **BASED ON A STATIC CYLINDER WHICH IS FREE FROM SWIVEL JOINTS (HELICAL REAMER) COUPLED WITH A MILLING TOOL THAT DETACHES THE ICE WITHOUT ANY STRAINED OR FORCED MOVEMENTS**
FUNCIONAMIENTO BASADO EN UN CILINDRO ESTÁTICO SIN JUNTAS GIRATORIAS (HELICAL REAMER) Y CON UNA FRESA QUE DESPEGA EL HIELO SIN TENSIONES NI ESFUERZOS
- ▶ **THE MOST EFFICIENT EVAPORATOR OF THE MARKET, LESS ENERGY CONSUMPTION AND HIGHER ICE PRODUCTION**
EL EVAPORADOR MAS EFICIENTE DEL MERCADO, MENOR GASTO ENERGÉTICO, MAYOR PRODUCCIÓN DE HIELO
- ▶ **THERMOSTATIC EXPANSION VALVE / LIQUID SOLENOID VALVE / STOP WHEN FULL ICE WITH PHOTOELECTRICAL SENSOR**
VÁLVULA DE EXPANSIÓN TERMOSTÁTICA / VÁLVULA SOLENOIDE DE LÍQUIDO / PARO POR LLENADO CON CÉLULA FOTOELÉCTRICA
- ▶ **ELECTRONIC STOP SYSTEM / ELECTRICAL CONTROL PANEL / DRIVE DIRECT GEAR MOTOR / MAGNETIC DRIVE PUMP / LOW WATER SAFETY DEVICE**
SISTEMA DE PARO ELECTRÓNICO / CUADRO ELÉCTRICO DE REGULACIÓN / MOTORREDUCTOR DE ATAQUE DIRECTO / BOMBA DE ARRASTRE MAGNÉTICO / SEGURIDAD DE FALTA DE AGUA
- ▶ **STAINLESS STEEL SOLEPLATE EVAPORATOR**
BANCADA DE ACERO INOXIDABLE EVAPORADOR
- ▶ **CONTROLLER TO DETECT: LOW WATER LEVEL, ROTATION IN OPPOSITE DIRECTION, TEMPERATURE INCREASE DUE TO AN OVERLOADED MOTOR OR DUE TO OVERFULL STORAGE**
CONTROLADOR PARA DETECTAR: FALTA DE AGUA, GIRO AL REVÉS, SUBIDA DE TEMPERATURA POR SOBRESFUERZO EN EL REDUCTOR O POR LLENADO DE ALMACÉN



	 24 H (Kg)	 10° 10° (Kg)	 21° 15° (Kg)	 (mm)	 (mm)	
SCALA 3T SPLIT	3.300	3.000		Width 1.050 Depth 750 Height 1.300	Width 1.050 Depth 975 Height 1.330	FLAKE ICE

ACCESORIES ACCESORIOS

INCLUDED



WATER INLET FILTER GASKET
JUNTA DE FILTRO

WATER INLET MANGUERA DE ENTRADA DE AGUA

WATER OUTLET DRENAJE

OPTIONAL (NOT INCLUDED)

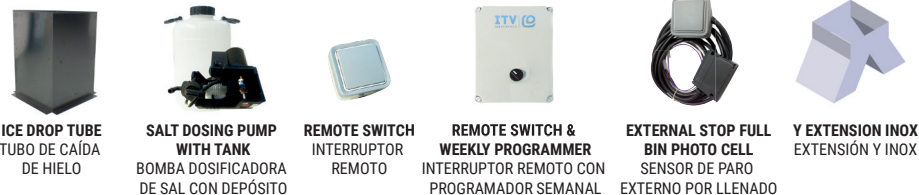

ICE DROP TUBE TUBO DE CAÍDA DE HIELO

SALT DOSING PUMP WITH TANK BOMBA DOSIFICADORA DE SAL CON DEPÓSITO

REMOTE SWITCH INTERRUPTOR REMOTO

REMOTE SWITCH & WEEKLY PROGRAMMER INTERRUPTOR REMOTO CON PROGRAMADOR SEMANAL

EXTERNAL STOP FULL BIN PHOTO CELL SENSOR DE PARO EXTERNO POR LLENADO

Y EXTENSION INOX EXTENSIÓN Y INOX

RECOMMENDED BINS SILOS RECOMENDADOS



S500

S700

SCD400

SCD600

SCD800

SS 221 2000kg

SS 422 4000kg

TECHNICAL SCHEME ESQUEMA TÉCNICO

SCALA 3T SPLIT

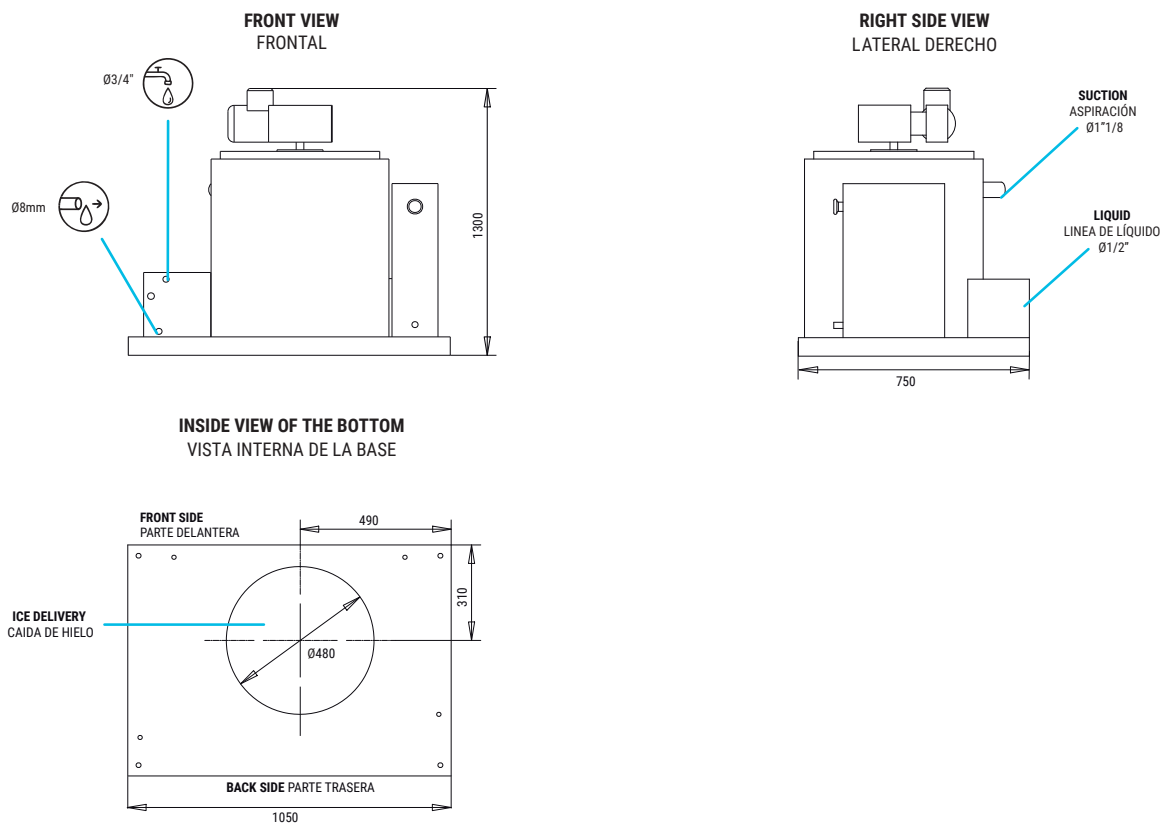

* All measurements in mm.
* Todas las cotas en mm.

OPERATING CONDITIONS CONDICIONES DE OPERACIÓN

PRODUCTION 50Hz PRODUCCIÓN 50Hz

±10% V

5°C/43°C

5°C/35°C

1 bar/6 bar

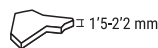
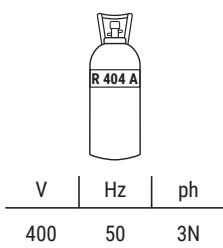

24 H		SCALA 3T SPLIT			
°C	°F	10°	15°	21°	30°
10°	50°	3300	3100	2700	2500
21°	68°	3270	3000	2600	2370
32°	90°	3100	2800	2400	2150
43°	109°	2550	2370	1950	1800

24 H		SCALA 3T SPLIT			
°C	°F	10°	15°	21°	30°
10°	50°	3300	3100	2700	2500
21°	68°	3270	3000	2600	2370
32°	90°	3100	2800	2400	2150
43°	109°	2550	2370	1950	1800

MODELS MODELOS

Temp.EV. (°C)	(W)	(BTu/h)	(n.)	(mm ²)	(W)	FUSE	(kW/h)	(l/h)	HEAT REJECTED (W) (BTu/h)	(Kg)	(Kg) (m ³)
---------------	-----	---------	------	--------------------	-----	------	--------	-------	---------------------------	------	------------------------

SCALA 3T SPLIT

-22	16.500	56.300	5	1,5	200	16	7,8 *	125	-	-	280	-	1,49
-----	--------	--------	---	-----	-----	----	-------	-----	---	---	-----	---	------



INDUSTRIA TÉCNICA VALENCIANA, S.A.
POL. IND. SECTOR 13, AVDA. DELS HOSTALERS, 2
46394 RIBARROJA DE TURIA, VALENCIA, SPAIN
PHONE: +34 96 166 75 75 | FAX: +34 96 166 81 00
comercial@itv.es | www.itv.es



SERVICE
SERVICIO ASISTENCIA TÉCNICA
service@itv.es
Skype: ITV.Service
+34 961 667 639
8:00AM | 7:00PM



Subject to certain limitations and exclusions. Only spare parts. Sujeto a limitaciones y exclusiones. Solo piezas de repuesto.

